



**BREAKER
TECHNOLOGY,
INC.**

an Astec company

ALBT SERIES

ANFO Loading Vehicle

BTI's ALBT Series of ANFO Loading Vehicle is a heavy duty, low profile unit specifically designed for various explosive loading, underground applications.

Features & Benefits

Coverage Options

3 models available with 11, 13 and 15 foot extension booms for various face loading requirements.

Turret Mounted Boom

Easily allows up to 270 degrees of boom rotation for single, double or triple face coverage



ALBT11
on LP15ARW Carrier

Worm Driven Swing Drive

Positive drive for the Turret and Basket Swing c/w spring applied and hydraulic release brakes for smooth operations control and positive hold.

Long Life, Solid Stainless Steel Tanks

Single and double tank layouts - available from 540 lbs to 2,100 lbs capacity. Single, double or triple loading hoses can be switched from Tank A or B or operate from both.

Heavy Duty Stabilizers

Two vertical front and two rear out and down jacks provide positive boom stability.

ALBT Series ANFO Loading Vehicles

	ALBT 11	ALBT 13	ALBT 15	
A	in mm	128 3,258	128 3,258	128 3,258
B		38%	38%	38%
C	in mm	70 1,778	70 1,778	70 1,778
D	in mm	112 2,845	112 2,845	112 2,845
E	in mm	189 4,802	196 5,042	224 5,695
F	in mm	451 11,457	461 11,704	486 12,350
G		21%	21%	21%
H	in mm	85 2,164	77 1,955	49 1,243
J	in mm	18 457	18 457	18 457
K	in mm	290 7,371	316 8,034	357 9,068
L	in mm	R313 R7946	R319 R8105	R335 R8508
M	in mm	R163 R4137	R163 R4137	R163 R4137
N	in mm	96 2,438	96 2,438	96 2,438
O	in mm	171 4,355	171 4,355	171 4,355
P	in mm	198 5,021	204 5,180	220 5,583

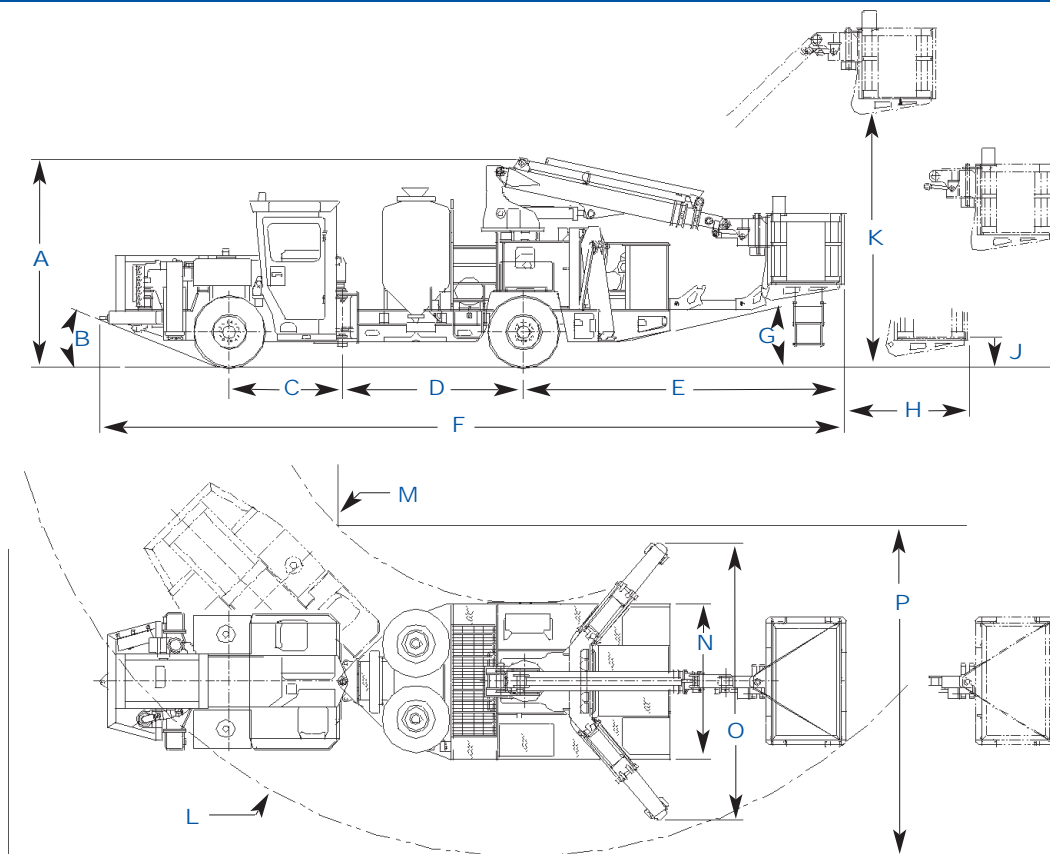

Dimensions & Specifications	ALBT11	ALBT13	ALBT15
Basket Size	72" x 42" x 42"	182 mm x 106 mm x 106 mm	
Basket Swing	+/- 65 degree		
Basket Swing Type	Totally enclosed gear driven bearing with one hydraulic motor		
Basket Capacity	1000 lbs	454 kg	
Basket Leveling	Self-leveling hydraulic slave cylinder with override		
Removable Basket	Standard pin-on connection		
Cap and Stick Powder Storage	2 bins located in basket		
Boom Extension Type	2 x single stage, double acting hydraulic cylinder		
Boom Lift	Double acting hydraulic cylinder complete with load drop check valves		
Boom Swing	270 degree rotation		
Boom Swing Type	Totally enclosed gear driven bearing with two hydraulic motors		
Boom Brake	Two spring applied hydraulic release, fail safe		
Boom Extension Distance	142" / 360.68 mm	156" / 396 mm	180" / 4572 mm
Maximum Face Width	46.5 ft / 14.17 m	53 ft / 16.15 m	59 ft / 17.98 m
Maximum Face Height	29 ft / 8.83 m	31 ft / 9.44 m	35 ft / 10.66 m

All dimensions and specifications are approximate and subject to change without notice.

Enclosed operator compartment complete with heater and air conditioner for operations comfort. Sound insulated for noise control.
In-basket electro-hydraulic joy stick control and on-board vehicle mounted valves.

Options:
Emulsion loading system
Electric/Hydraulic power pack
Hydraulic driven piston type air compressor - 85 to 160 cfm



BREAKER TECHNOLOGY an Astec Industries Company

UNITED STATES EAST 440.248.7168 • UNITED STATES WEST 951.369.0878 • CANADA/INTERNATIONAL 519.599.2015 • rockbreaker.com

