

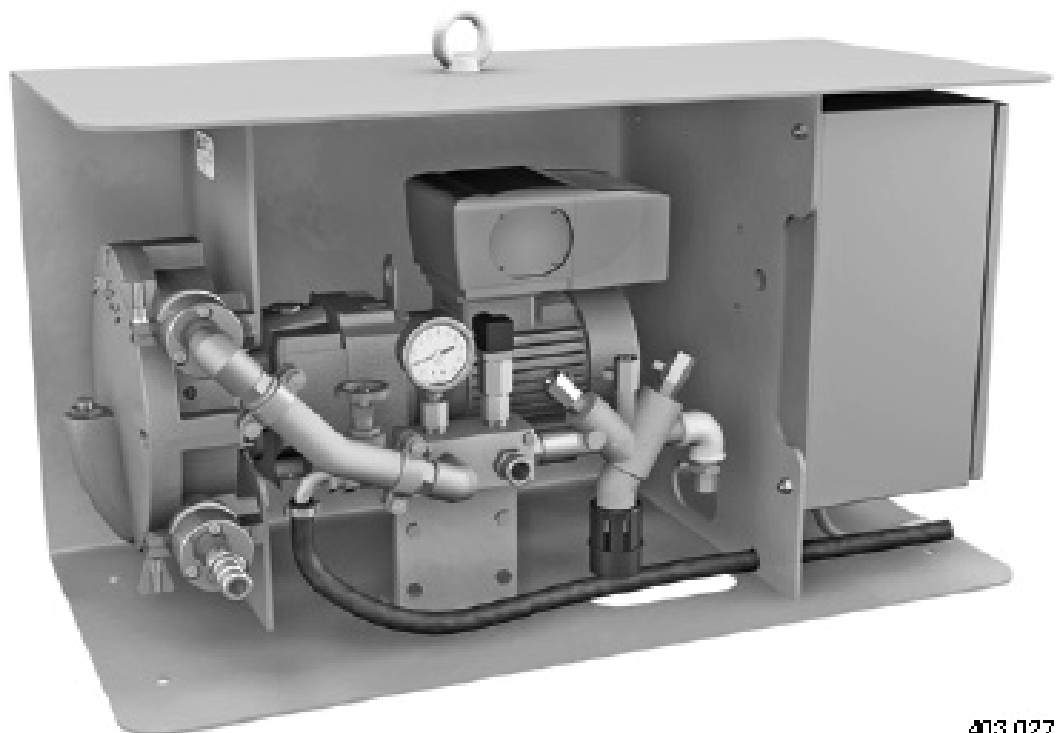

## AL-403.6 Liquid dosing unit



403.027

- High capacity**
- Entire range of additives**
- Continuous adjustable output**
- Automatic synchronisation adjustment**

## Technical Data

The AL-403.6 for liquid additives enables water-independent dosing of additives. The conveying can be set infinitely.

The **MANUAL** version is equipped with a simple control box. Operating is done entirely on the dosing unit itself. The amount of additives is set manually by means of the dosing knob.

The **SYNCHRO** version can be connected via control cable with the concrete spraying machine. Operating of the dosing unit is carried out by remote control from the concrete spraying machine. If the conveying capacity of the concrete machine is changed automatically the amount of additives will proportionally be adjusted.

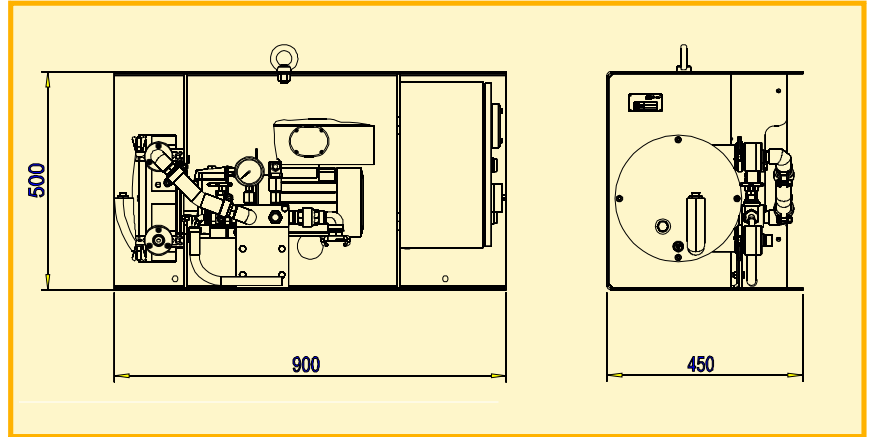

### Dimensions

Length	900 mm
Width	450 mm
Height	500 mm
Weight approx.	130 kg

### Theoretical conveying data

Output DL 10	24-240 l/h
Output DL 18	30-700 l/h
Output pressure max.	10-bar (max.)

### Connecting variation

V Voltage	1x230V	3x230V	3x400V
A Ampere	7 A	7 A	5 A
gG Fuses	16 gG	16 gG	10gG

### Electric motor drive

Motor output	0,75 kW
Voltage	380-480V 50/60Hz
Protection	IP 55

### Wet process in thin stream

- 1 Compressed air
- 2 Wet material
- 3 Filling hopper
- 4 Compressed air
- 5 Conveyor hose
- 6 Compressed air Additive
- 7 Nozzle
- 8 Spraying
- 9 Additive

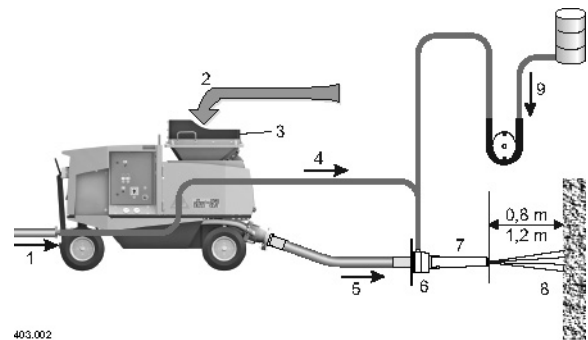

403.002

Datas for the dosing unit with air drive on request.

Technical and design modifications remain reserved at all times. Technical properties have been achieved under theoretical and normal conditions. Please consult the respective machine manual for all matters related to operations and maintenance.

For us a matter of principle



Your local dealer

Authorized Distributor: