

At A Glance

Operating Weights: lb. (kg.)

Model	Boom only	Complete System*
MRHT16.....	12,043 (5462)	18,027 (8176) – 22,343 (10133)
MRHT20.....	12,443 (5643)	18,337 (8316) – 21,103 (9571)
MRHT2025...	12,743 (5779)	18,637 (8452) – 20,743 (9407)
MRHT25.....	13,243 (6006)	19,237 (8724) – 21,343 (9679)

* complete system from smallest to largest appropriate hammer, including electric-hydraulic power pack and controls

Dimensions: in (mm)

Model	Length x Width*	Working length**	Base (L x W)
MRHT16.....	251 x 53.5 (6375 x 1359)	183.0 (4648)	62.75 x 53.5 (1594 x 1359)
MRHT20.....	297 x 53.5 (7544 x 1359)	229.4 (5827)	62.75 x 53.5 (1594 x 1359)
MRHT2025..	333 x 53.5 (8458 x 1359)	265.2 (6736)	62.75 x 53.5 (1594 x 1359)
MRHT25.....	352 x 53.5 (8941 x 1359)	277.1 (7038)	62.75 x 53.5 (1594 x 1359)

* less hammer

** swing pivot to dipperstick / hammer mounting pin (on-center) dimension

Operating Parameters

Model	Hammer Model Range: ft-lb (J)
MRHT16.....	BX20: 2000 (2711) thru BXR85: 8500 (11524)
MRHT20.....	BX20: 2000 (2711) thru BXR65: 6500 (8812)
MRHT2025...	BX20: 2000 (2711) thru BXR50: 5000 (6779)
MRHT25.....	BX20: 2000 (2711) thru BXR50: 5000 (6779)

MRHT SERIES

Rockbreaker System



FEATURES & BENEFITS

High strength steel (bent, 4-plate) construction
65 ksi tensile strength; 50 ksi yield strength for longer service life

Reinforced pivot and mounting pin joints with improved durability

Hardened steel bushings in pivot joints and larger diameter pivot pins provide reduced bearing pressure and increased service life

Thicker pedestal base plate – 1.5" (38 mm)

Pedestal mounting bolt pattern matches TM-H & X MRH series for ease of installation and reduced expense of replacement

Increased cross sectional strength of boom and dipper where high stress is realized

Common cylinder for hoist (lift), crowd (stick) and curl (tilt) functions

Tilt & Lift valve stand for improved serviceability

Legend: ● Standard ▲ Optional

MRHT Series Pedestal Rock Breaker System

BOOM & HAMMER COMBINATIONS

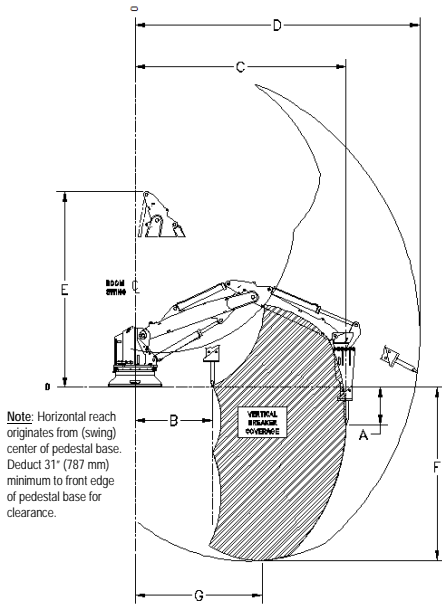

Hammer Specifications

Hammer Models:	BX20	BX30	BX40	BXR50	BXR65	BXR85
Impact Energy Class: ft-lb (J)	2000 (2711)	3000 (4067)	4000 (5423)	5000 (6779)	6500 (8812)	8500 (11524)
Operating Weight: lb. (kg.)	2094 (950)	2866 (1300)	3749 (1700)	3880 (1760)	4563 (2070)	6463 (2931)
Working Length: in. (mm)	90.4 (2295)	99.8 (2535)	108.8 (2764)	107.0 (2718)	110.8 (2813)	127.6 (3240)
Tool Diameter: in. (mm)	4.2 (105)	4.8 (120)	5.1 (135)	5.5 (140)	5.9 (150)	6.3 (160)
Operating Flow: gpm (lpm)	24-29 (90-100)	27-37 (100-140)	29-42 (110-160)	38-54 (144-204)	42-60 (158-227)	52-75 (197-284)
Operating Pressure: psi (bar)	1740-2320 (120-160)	1740-2465 (120-170)	1885-2465 (120-170)	2180-2760 (150-190)	2180-2760 (150-190)	2180-2760 (150-190)
Impact Frequency: bpm (short stroke)	350-600	400-600	380-600	374-611 (514-840)	341-561 (454-746)	328-544 (436-723)
Sound / Distance* at 85 dB(A): ft. (m)	100 (30)	121 (37)	135 (41)	142 (43)	146 (44)	150 (45)

(*): BX & BXR hammers are furnished with a sound suppressing housing for superior noise attenuation. Noise levels may vary due to site conditions and barriers.

Coverage

	MRHT16						MRHT20						MRHT20S				MRHT25			
--	--------	--	--	--	--	--	--------	--	--	--	--	--	---------	--	--	--	--------	--	--	--

ft. (m)	BX20	BX30	BX40	BXR50	BXR65	BXR85	BX20	BX30	BX40	BXR50	BXR65	BX20	BX30	BX40	BXR50	BX20	BX30	BX40	BXR50
A	3'-2" (1.0)	4'-0" (1.2)	4'-9" (1.9)	4'-7" (1.4)	4'-11" (1.5)	6'-3" (1.91)	3'-8" (1.1)	4'-6" (1.4)	5'-3" (1.6)	5'-1" (1.5)	6'-9" (2.1)	3'-10" (1.2)	4'-8" (1.4)	5'-5" (1.7)	5'-3" (1.6)	3'-10" (1.2)	4'-8" (1.4)	5'-5" (1.7)	5'-3" (1.6)
B	6'-11" (2.1)	6'-11" (2.1)	6'-11" (2.1)	6'-11" (2.1)	6'-11" (2.1)	6'-11" (2.1)	7'-5" (2.3)	7'-5" (2.3)	7'-5" (2.3)	7'-5" (2.3)	7'-5" (2.3)	6'-7" (2.0)	6'-7" (2.0)	6'-7" (2.0)	6'-7" (2.0)	6'-7" (2.0)	6'-7" (2.0)	6'-7" (2.0)	6'-7" (2.0)
C	16'-5" (5.0)	16'-5" (5.0)	16'-5" (5.0)	16'-5" (5.0)	16'-5" (5.0)	16'-5" (5.0)	20'-1" (6.1)	20'-1" (6.1)	20'-1" (6.1)	20'-1" (6.1)	20'-1" (6.1)	21'-7" (6.6)	21'-7" (6.6)	21'-7" (6.6)	21'-7" (6.6)	24'-7" (7.5)	24'-7" (7.5)	24'-7" (7.5)	24'-7" (7.5)
D	23'-5" (7.1)	23'-11" (7.3)	24'-5" (7.5)	24'-3" (7.5)	24'-7" (7.5)	25'-9" (7.9)	27'-5" (8.4)	27'-11" (8.5)	28'-5" (8.7)	28'-3" (8.6)	28'-7" (8.7)	29'-6" (8.9)	29'-7" (9.0)	30'-1" (9.2)	29'-11" (9.1)	32'-1" (9.8)	32'-7" (9.9)	33'-1" (10.1)	32'-11" (10.0)
E	17'-2" (5.2)	17'-2" (5.2)	17'-2" (5.2)	17'-2" (5.2)	17'-2" (5.2)	17'-2" (5.2)	18'-8" (5.7)	18'-8" (5.7)	18'-8" (5.7)	18'-8" (5.7)	18'-8" (5.7)	18'-8" (5.7)	18'-8" (5.7)	18'-8" (5.7)	18'-8" (5.7)	21'-6" (6.6)	21'-6" (6.6)	21'-6" (6.6)	21'-6" (6.6)
F	13'-8" (4.2)	14'-4" (4.4)	15'-3" (4.6)	15'-1" (4.6)	15'-5" (4.7)	16'-9" (5.1)	15'-8" (4.8)	16'-6" (5.0)	17'-3" (5.3)	17'-1" (5.2)	17'-9" (5.4)	19'-6" (5.9)	20'-4" (6.2)	21'-1" (6.4)	20'-11" (6.4)	20'-4" (6.2)	21'-2" (6.4)	21'-11" (6.7)	21'-9" (6.6)
G	10'-4" (3.1)	10'-4" (3.1)	10'-4" (3.1)	10'-4" (3.1)	10'-4" (3.1)	10'-4" (3.1)	11'-11" (3.6)	11'-11" (3.6)	11'-11" (3.6)	11'-11" (3.6)	11'-11" (3.6)	13'-3" (4.0)	13'-3" (4.0)	13'-3" (4.0)	13'-3" (4.0)	15'-0" (4.6)	15'-0" (4.6)	15'-0" (4.6)	15'-0" (4.6)

Tool Selection (for aggregate production and mining)



- **Blunt** is used for boulder and oversize breaking; tool impact delivers the stress wave generated by the hammer causing the material to fracture; excellent wear resistance



- **Chisel** is suitable for slabby, angular material; tool provides wedge effect impact and good penetration



- **Moil** is ideal for softer, abrasive material where high penetration is needed; similar to the blunt it results in less torque in the front head

Concave Removal Tool

For Gyrotory Crusher

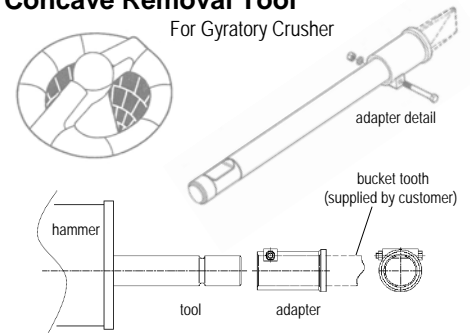

Note: Adapter tool length is 72 in. (1829 mm) long plus adapter and tooth

MRHT Series Pedestal Rock Breaker System

HAMMER SELECTION GUIDE FOR BLASTED MATERIAL*

IMPERIAL MEASUREMENTS

Material Hardness Compressive Strength	BOULDER SIZE - yd ³						
	< 0.5 yd ³	0.5 – 1.0 yd ³	1.0 – 2.0 yd ³	2.0 – 4.0 yd ³	4.0 – 6.0 yd ³	6.0 – 8.0 yd ³	8.0 – 10 yd ³
Very Hard..... 35-45 ksi examples: gneiss, schist, andesite, gold ore	2,000 ft-lb	3,000 ft-lb	4,000 ft-lb	5,000 ft-lb	6,500 ft-lb	8,500 ft-lb	10,000 ft-lb
Hard..... 25-35 ksi examples: siliceous limestone, basalt, granite, trap rock, copper ore	1,500 ft-lb	2,000 ft-lb	3,000 ft-lb	4,000 ft-lb	5,000 ft-lb	6,500 ft-lb	8,500 ft-lb
Medium Hard... 15-25 ksi examples: dolomite, siliceous and dolomitic limestone	1,000 ft-lb	1,500 ft-lb	2,000 ft-lb	3,000 ft-lb	4,000 ft-lb	5,000 ft-lb	6,500 ft-lb
Soft..... 10-15 ksi examples: soft limestone, gypsum	800 ft-lb	1,000 ft-lb	1,500 ft-lb	2,000 ft-lb			

(*): 1 ksi = 1,000 psi (lbs. / in.²), ranges provided due to possible layer presence and density variance.

METRIC MEASUREMENTS

Material Hardness Compressive Strength	BOULDER SIZE - m ³						
	< 0.5 m ³	0.5 – 1.0 m ³	1.0 – 2.0 m ³	2.0 – 4.0 m ³	4.0 – 6.0 m ³	6.0 – 8.0 m ³	8.0 – 10.0 m ³
Very Hard..... 241-310 MPa examples: gneiss, schist, andesite, gold ore	3,000 ft-lb	4,000 ft-lb	5,000 ft-lb	6,500 ft-lb	8,500 ft-lb	10,000 ft-lb	12,000 ft-lb
Hard..... 172-241 MPa examples: siliceous limestone, basalt, granite, trap rock, copper ore	2,000 ft-lb	3,000 ft-lb	4,000 ft-lb	5,000 ft-lb	6,500 ft-lb	8,500 ft-lb	10,000 ft-lb
Medium Hard.. 103-172 MPa examples: dolomite, siliceous and dolomitic limestone	1,500 ft-lb	2,000 ft-lb	3,000 ft-lb	4,000 ft-lb	5,000 ft-lb	6,500 ft-lb	8,500 ft-lb
Soft..... 69-103 MPa examples: soft limestone, gypsum	1,000 ft-lb	1,500 ft-lb	2,000 ft-lb	3,000 ft-lb			

(*): 1 MPa = 145 psi (lbs. / in.²), ranges provided due to possible layer presence and variance.

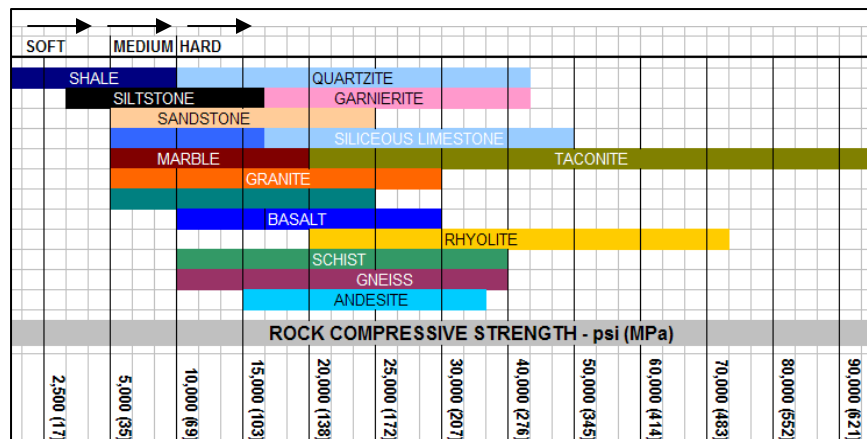

MRHT Series Pedestal Rock Breaker System

DESIGN and ENGINEERING DATA

Design Data: in (mm)

- Mounting bolt size: 1.5 in. dia. (ø 38) x7 thru holes @ 1.75 in. dia. (ø 44)
- Mounting bolt torque: 1,450 ft-lb (1,966 N-M)
- Swing Angle: 330° (-165° / +165°) ●
- 81CC Swing Motor – 2000 psi (138 bar) Internal Relief

Pivot Pin Data: in. (ø mm)

- 4.0 (ø 102) Pedestal Base-to-Hoist Boom; Hoist Boom-to-Dipperstick (Jib)
- 3.0 (ø 76): Hammer Mounting

Cylinder data: Bore ø / Rod ø / Stroke

- Hoist (lift): 6.0 / 3.50 / 48.5 (152 / 89 / 1232)
- Stick (crowd): 6.0 / 3.50 / 48.5 (152 / 89 / 1232)
- Tilt (curl): 6.0 / 3.50 / 48.5 (152 / 89 / 1232)

Cylinder mounting pins

- 3.0 (76)
- 3.0 (76)
- 3.0 (76)

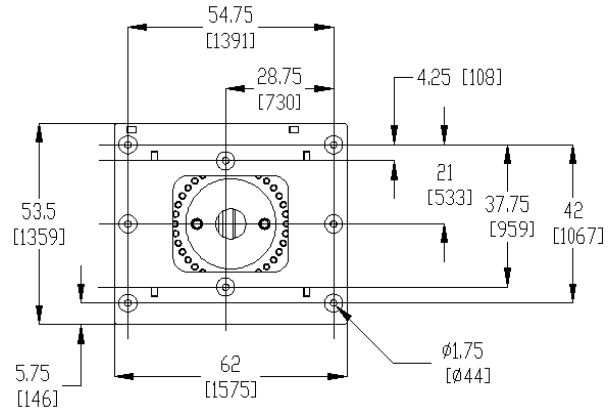

Pedestal Base Dimension: MRHT16 - MRHT20 - MRHT2025 - MRHT25

Engineering Data: Loads and Moments

Imperial

Static Overturning

Moments: ft-lb (+/-)

- MH*: 267,000 / 0
- MV: 23,400 / 23,400
- MS*: 267,000 / 267,000

Loads: lbs. (+/-)

- FS*: 10,105 / 10,105
- FV: 0 / 22,000
- FH*: 10,105 / 10,105

Dynamic Overturning

Moments: ft-lb (+/-)

- MH: 534,000 / 0
- MV: 46,800 / 46,800
- MS: 534,000 / 534,000

Swing Torque: 23,400 ft-lb

Metric

Static Overturning

Moments: kN-M (+/-)

- MH*: 362 / 0
- MV: 32 / 32
- MS*: 362 / 362

Loads: kN (+/-)

- FS*: 45 / 45
- FV: 0 / 96
- FH*: 45 / 45

Dynamic Overturning

Moments: kN-M (+/-)

- MH: 724 / 0
- MV: 64 / 64
- MS: 724 / 724

Swing Torque: 32 kN-M

(*): FS or FH and MH or MS are swing function results and do not happen simultaneously

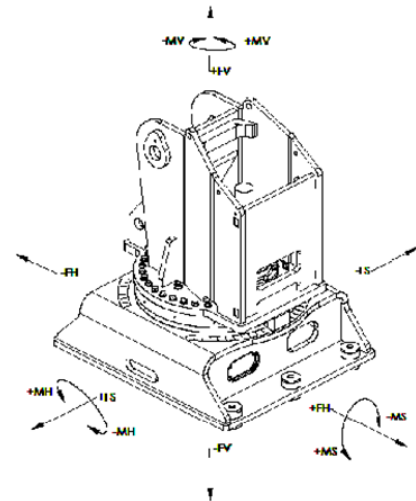

MRHT16 - MRHT20 - MRHT2025 - MRHT25

Cross Sectional Data: Section Height x Width - in (mm)

	Hoist / Inner Boom	Dipperstick / Outer (Jib) Boom
MRH16.....	18.4 x 15.5 (468 x 394)	24.3 x 11.5 (616 x 292)
MRH20.....	18.4 x 15.5 (468 x 394)	25.6 x 11.5 (649 x 292)
MRH2025.....	18.4 x 15.5 (468 x 394)	29.4 x 11.5 (748 x 292)
MRH25.....	18.4 x 15.5 (468 x 394)	29.4 x 11.5 (748 x 292)

Lifting Capacities: lb. (kg.)

- MRHT16..... 10,829 (4922)
- MRHT20..... 7,750 (3523)
- MRHT2025..... 6,500 (2948)
- MRHT25..... 5,250 (2386)

Calculated at full extension, value increases closer to the swing post



MRHT Series Pedestal Rock Breaker System

HYDRAULIC and ELECTRICAL SYSTEMS

Power Pack Specifications

Power Pack (PP) Model (Reservoir size - Hp)	PP100-50	PP100-60	PP100-100	PP100-100	PP100-100	PP100-125
Matched w/ Hammer Model	BX20	BX30	BX40	BXR50	BXR65	BXR85
Horsepower (kW)	50 (37)	60 (45)	100 (75)	100 (75)	100 (75)	125 (93)
Operating Weight: (w/o oil) lb. (kg.)	2000 (910)	2300 (1045)	2400 (1090)	2400 (1090)	2400 (1090)	3000 (1364)
Dimensions: L x W x H in. (mm)	66 x 36 x 60 (1676 x 914 x 1524)	66 x 36 x 81 (1676 x 914 x 2057)	66 x 36 x 81 (1676 x 914 x 2057)	66 x 36 x 81 (1676 x 914 x 2057)	66 x 36 x 81 (1676 x 914 x 2057)	66 x 36 x 81 (1676 x 914 x 2057)
Max. Pump Flow gpm (lpm)	60 (227)	60 (227)	60 (227)	60 (227)	60 (227)	60 (227)
Regulated Pump Flow gpm (lpm)	29 (110)	37 (140)	54 (204)	54 (204)	54 (204)	58 (220)
Pump Pressure psi (bar)	3600 (250)	3600 (250)	3600 (250)	3600 (250)	4200 (290)	4200 (290)
Pressure Filter Flow Capacity gpm (lpm)	60 (227)	100 (379)	147 (556)	147 (556)	147 (556)	147 (556)
Air-to-Oil Cooler ½ HP motor (56T frame)	c/w Optional	Standard	Standard	Standard	Standard	Standard

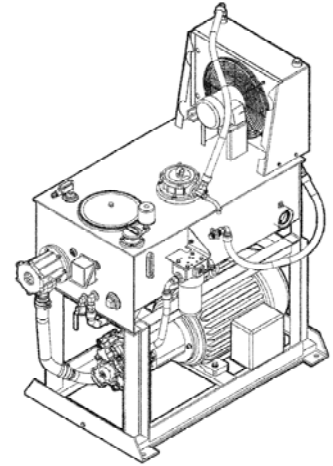

Filtration	Micron	Filtration Area sq. in. (sq. mm)	Flow Capacity gpm (lpm)	By-Pass psi (bar)	Maximum Pressure Rating psi (bar)
Pressure Filter	10	415 (2677)	varies - see chart above	75 (5)	5075 (350)
Return Filter	10	1100 (7100)	130 (490)	22 (1.5)	n/a
Suction Strainer	10	415 (2677)	60 (225)	75 (5)	6,000 (410)

Electric Motor (Pump Drive)	50 HP	60 HP	100 HP	125 HP
TEFC (IP55) Frame Size High Efficiency Prem. Efficiency	326T	364/5T	404/5T	404/5T 444/5T
RPM / Service Factor	1800 / 1.25	1800 / 1.25	1800 / 1.25	1800 / 1.15
Efficiency & Power Factor @ 100%	94.5 / 84.0	95.0 / 87.0	95.4 / 87.0	95.8 / 88.0
AC Voltage / Phase / Hertz (other combinations available to suit site)	380 / 3 / 50 460 / 3 / 60 575 / 3 / 60	380 / 3 / 50 460 / 3 / 60 575 / 3 / 60	380 / 3 / 50 460 / 3 / 60 575 / 3 / 60	380 / 3 / 50 460 / 3 / 60 575 / 3 / 60
Current: Full Load / Locked Rotor (amps)	58.4 / 355	68.0 / 430	112 / 725	139 / 907
Torque: Full Load Torque ft-lb (N-m)	148 (201)	177 (240)	295 (400)	368 (499)

Note: Power Pack Assembly also includes Pressurized reservoir capacity is 100 gal. (353 liters); Vent pressure relief is 4 psi (2.8 bar); Visual indicators provided on both pressure and return filters; low-oil level cut-off switch; pressurized filler cap., tank clean-out access cover; oil level gauge; temperature gauge; pump load sense bulkhead & connector, drain port & valve

Power Pack (HPU) Options

Oil Tank Immersion Heater c/w thermostat; High/Low Temperature Sensor; Motor Starter Panel; Recirculation Valve; High Altitude Provision; Motor Deration Package in 3,281 ft. (1000 meters); Drip tray; Hand pump; Motor Terminal Blocks; Water-over-Air Cooler pkg.; Cold Weather Conversion Kit

Note: NEMA Design B; Class "F" insulation; Altitude 3,300 ft. (1000 m) a.s.l.; Ball bearings; Continuous duty; Energy savings > EFF1 minimum efficiency (CC029A certification); Premium eff. meets IEEE841 standard

Remote Controls

Electric-Hydraulic Control Console

- Sturdy Framed Stand – 48 in. (1219 mm) height
- 2-Dual Axis Joysticks – R.H. Thumb Hammer Op.
- SAE Mapping / Excavator Control Pattern
- Console On/Off Button
- Pedestal EHC Enclosure
- 30 ft. (9.1 m)* cable
- Powered by local 110/115 VAC

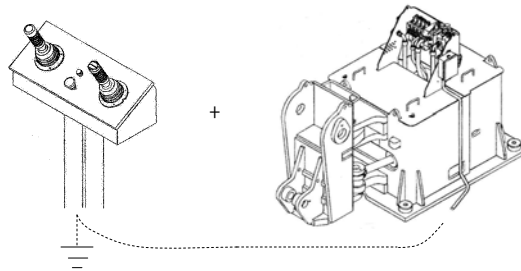

Additional Electric-Hydraulic Control Options

- Remote Control Panel for remote start/stop of power pack, c/w indicator switches / lamps
- Additional length remote control umbilical cable length > 30 ft. (9.1 m)
(See distance options below)

Control System Options

Portable Electric- Hydraulic Control	Radio Remote Control (transmitter & receiver system)	Manual Control Console	Ergonomics Operator's Seat c/w Electric-Hydraulic Control

Distance Options ft. (m)

- Standard EHC configuration - 100 (30) to 200 (60)
- Deluxe EHC configuration - 200 (60) to 400 (120)
- Radio Remote option - 328 (30) max.
- Parker IQAN (can-bus) option - 328 (30) max.
- Coaxial Cable (Pan-Zoom Camera) option – 1,500 (457)
- Fiber Optics (Pan-Zoom Camera) option – 7 miles (11.2K m)

MRHT Series Pedestal Rock Breaker System

OPTIONS[▲]

BOOM

- All hose system
- Counter balance valves
- Anti-lunge protection
- Anti-blank fire interlock
- Foundation interface mounting
- concrete or steel structure
- Greasing systems
- manual, hydraulic or pneumatic
- Fire Suppression (Ansul)
- Explosion proof valve/circuit
- Auxiliary hydraulic circuit
- Steel isolator mounting
- Customized base mounting*
- Swing stops & alt. positioning
- Expander pin provision
- Spring guard hose covering
- Start-up / commissioning svc.
- Installation supervision



(*) Expander pin provision

POWER PACK

- Immersion heater
- High/Low temperature sensor
- Continuous circulation valve
- Premium efficient motor
- Motor Starter Panel
- additional mounting & wiring
- Cooler Package (for BX20)
- air-to-oil or water-to-oil
- Cold weather conversion kits
- High altitude provision
- Motor deration package
- Motor terminal blocks
- Explosion proof motor
- Hand pump / Drip tray
- Drip tray
- Dust enclosure w/ ventilation

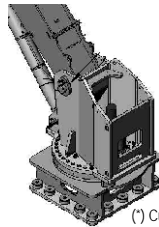

(*) Customized base mounting

CONTROLS

- Radio remote controls
- Portable remote controller
- Remote mechanical controls
- Remote starter panel
- Secondary remote controller
- stand or portable
- Longer remote cables
- standard / deluxe cabling
- IQAN* (can bus) control system
- Ergonomic chair c/w controls
- Coaxial cable system
- Fiber optics system



(*) IQAN (can-bus) control system

HAMMER

- Severe duty wear kit
- Rock claws kit
- Mechanic quick coupler
- Concave removal tool
- Spare Tools
- blunt, chisel,moil
- Chisel paste
- single tube or case or 5 gal. pail
- Extension mounting bracket

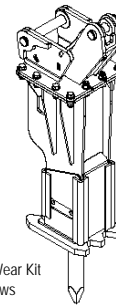

(*) Severe Duty Wear Kit c/w Rock Claws

MISCELLANEOUS

- 18 in (472 mm) bucket
- Quick Coupler-bucket
- Hydraulic positioner & circuit
- Control cabin (medium or large)*
- Control cabin options
- a/c; heater; extra door/window; etc.
- Miscellaneous attachments:
- picks, grapples, stone grabs

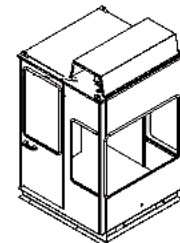

(*) Control Cab c/w A/C

A BTI representative is available to review your rock breaker project requirements and provide a site visit and assessment of your material flow conditions. BTI has a policy of continuous product improvement and reserves the right to revise or change designs and specifications at any time without obligation.

Authorized Dealer

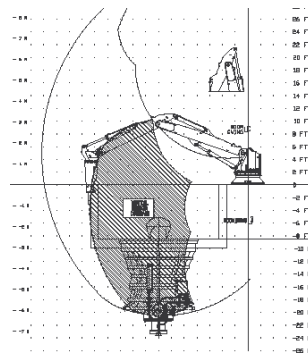

BREAKER TECHNOLOGY an Astec Industries Company

UNITED STATES EAST 440.248.7168 • UNITED STATES WEST 951.369.0878 • CANADA/INTERNATIONAL 519.599.2015 • rockbreaker.com



Rockbreaker Boom Systems Warranty Policy

REV 09/04

WARRANTY POLICY

1. BREAKER TECHNOLOGY INC. Company (hereinafter referred to as "BTI") warrants this product against defects in materials and workmanship for a period of twelve (12) months or 2000 hours from the date of installation, or 18 months from the date of shipment, whichever comes first. This warranty does not cover o-rings, seals, fittings, hoses, breaker tools or other items considered normal wear items. These are covered by the Limited Warranty period of thirty (30) days. Warranty for propriety items such as valves, pumps, filters, electric motors, panels and componentry that are not manufactured by BTI, will be governed by the warranty terms of their manufacturer. This warranty is void if BTI's standard installation specifications and procedures are not adhered to.
2. BTI will authorize return of any defective components or sufficient evidence of such defect to a BTI warehouse. Such components or such evidence must clearly show that the defect was caused by faulty material or poor workmanship. Warranty claim will be accepted only if it is submitted on a proper claims form with proof of purchase and received within sixty (60) days from the date of discovery of the defect. Warranty claims will be considered only if the "Installation Notice" has been duly filled in and returned to BTI within thirty (30) days from the date of installation.
3. BTI will at it's option, repair or refurbish the defective part(s) without charge to the initial user or may elect to issue full or partial credit toward the purchase of a new part(s). The extent of credit issued, which will be in the form of a "Credit Memo", will be determined by pro-rating against the normal life of the part(s) in question.
4. BTI is not responsible for mileage, travel time, travel expenses, overtime labor, and any freight expenses required to facilitate the repair.
5. This warranty does not apply if the product has been damaged by accident, abuse, misuse, misapplication or neglect, or as a result of service, disassembly or modification, without BTI's express authorization.
6. BTI assumes no liability beyond the replacement of defective parts or materials and/or the correction of such defective parts or materials.
7. BTI neither assumes nor authorizes any other person to assume for it any liability in connection with the sale of its products other than that specifically stated herein.
8. THIS WARRANTY IS EXPRESSLY IN LIEU OF ANY AND ALL OTHER WARRANTIES. EXCEPT AS EXPRESSLY SET FORTH HEREIN, BTI MAKES NO REPRESENTATION OR WARRANTY, STATUTORY, EXPRESS OR IMPLIED, WITH RESPECT TO THE PRODUCTS MANUFACTURED AND/OR SUPPLIED BY BTI, WHETHER AS TO MERCHANTABILITY, FITNESS FOR A PARTICULAR PURPOSE OR ANY OTHER MATTER. IN NO EVENT, INCLUDING IN THE CASE OF A CLAIM OF NEGLIGENCE, SHALL BTI BE LIABLE FOR INCIDENTAL OR CONSEQUENTIAL DAMAGES.

www.rockbreaker.com

Breaker Technology, Inc.
30625 Solon Industrial Pkwy.
Solon, Ohio 44139 USA
(440) 248-7168 / 8645 Ph. / Fx.

Breaker Technology, Inc.
3453 Durahart Street
Riverside, CA 92507
(951) 369-0878 / 8281 Ph. / Fx.

Breaker Technology Ltd.
35 Elgin Street North
Thornbury, Ontario N0H 2P0
(519) 599-2015 / 6803 Ph. / Fx.

BREAKER TECHNOLOGY an Astec Industries Company



UNITED STATES EAST 440.248.7168 • UNITED STATES WEST 951.369.0878 • CANADA/INTERNATIONAL 519.599.2015 • rockbreaker.com